

Every pump tested in water to ensure pump meets performance curve.



### FEATURES/BENEFITS

#### PERFORMANCE

- Heads up to 133' TDH
- Flows up to 44 GPM

#### MOTOR

- Internal or external capacitor start/capacitor run 208-230v, oil filled motors with upper and lower ball bearings and thermal over load protection
- Constant bearing lubrication
- Maximum motor cooling
- Runs cooler and lasts longer
- Internal overload protection
- Quiet operation
- Fasteners and shaft made from rugged, corrosion resistant stainless steel

#### SEAL DESIGN

- Double seal, oil filled chamber
- Provides added leakage protection
- Optional seal failure feature

#### IMPELLER DESIGN

- Non-clog style, cast-iron vortex impeller
- Designed to generate higher heads and reduce clogging by foreign materials
- Provides non-overloading performance

#### CUTTER ASSEMBLY

- 440 SST (56-60 Rockwell)
- 24,000 cuts per second and 1.5 million cuts a minute
- Designed to reduce over loading and clogging

#### POWER CORD

- Sealed entry quick disconnect power cords
- Prevents water from entering the motor housing through a cut cord
- Easy to replace in the field without having to run a new power cord
- Available in lengths up to 100'

#### SWITCH

- Piggy-back switch design
- Defective switches can be diagnosed over the phone
- Pump can be operated manually or supplied with other piggy-back switches
- Switch can be replaced without having to replace the pump

### APPLICATIONS

Residential developments, commercial developments and wastewater applications



2 HP grinder pumps that have a 1 1/4" or 2" optional vertical discharge that handles up to 3" solids

### PERFORMANCE CURVE

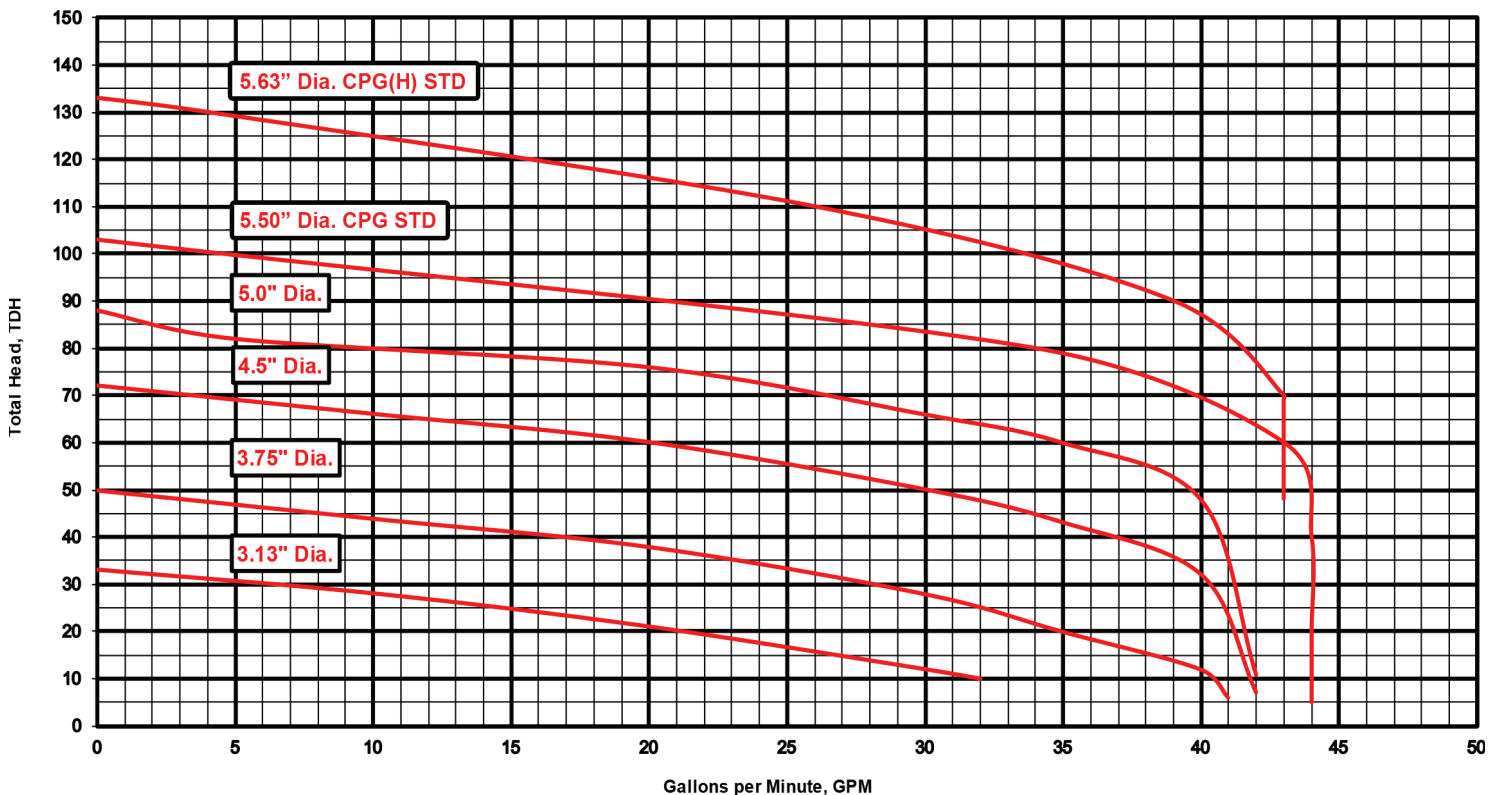

## TECHNICAL DATA

DISCHARGE	1 1/4" NPT. vertical standard or optional 2"
SOLIDS HANDLING	3"
LIQUID TEMPERATURE	150 Degrees F. (Intermittent)
MOTOR HOUSING	Cast Iron
VOLUTE	Cast Iron
SEAL PLATE	Cast Iron
IMPELLER	Cast Iron / Vortex
SHAFT	Stainless Steel
SHAFT SEAL (DOUBLE SEAL) with optional seal fail	Tandem double mechanical upper & lower, carbon ceramic, Buna-N elastomer, 300 stainless steel hardware
BEARINGS (UPPER & LOWER)	Single row, ball, oil lubricated
HARDWARE	300 Series stainless steel
O-RINGS	Buna-N
CORD	Quick disconnect 20' cord standard. Up to 30' with a plug and 100' available without a plug. 3 phase 30' cord standard. UL/CSA (SJOW) 14/3 (.375 OD) * UL/CSA (SO) Cord 14 Ga. (.60)
MOTOR (SINGLE PHASE)	2 HP 3450 RPM. 60 Hz, Includes overload protection in the motor, oil filled, class F permanent split capacitor
WEIGHT	75 lbs. Single seal (Manual) 85 lbs. Double seal (Manual)

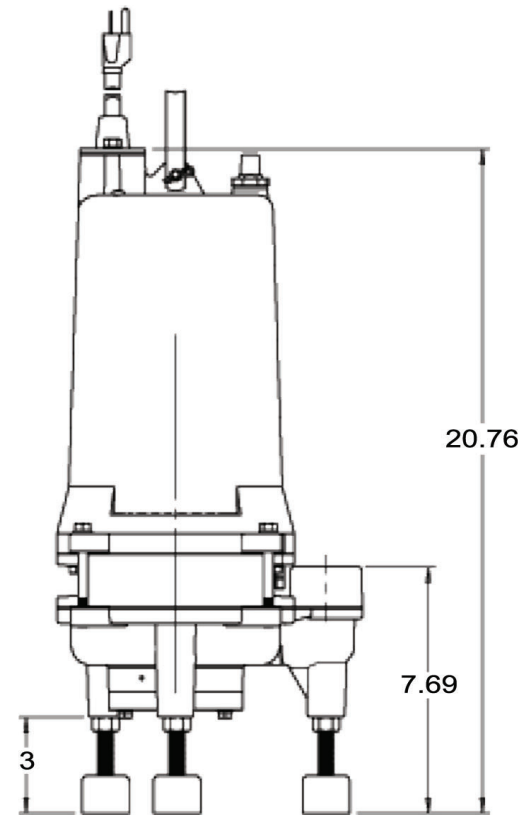
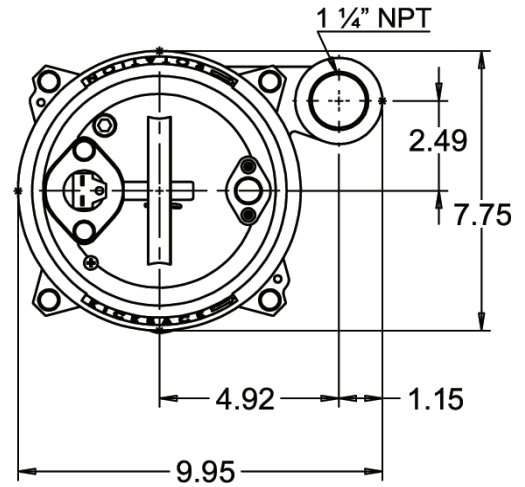

## MODEL(S) INFORMATION

MODEL	HP	VOLTS	PHASE	AMPS	CORD LENGTH	SWITCH	REQUIRES PANEL
CPG2022DS(A)	2	208/230	1	17/15	20'	M (Wide-Angle Float)	No
CPG2023DS(A)	2	208/230	1	17/15	30'	M (Wide-Angle Float)	No
CPG2023DSL	2	208/230	1	17/15	30'	Manual	Yes
CPG2033DSL	2	208/230	3	10/9	30'	Manual	Yes
*CPG2043DSL	2	460	3	4.5	30'	Manual	Yes