

INSTALLATION, SERVICE & PARTS MANUAL

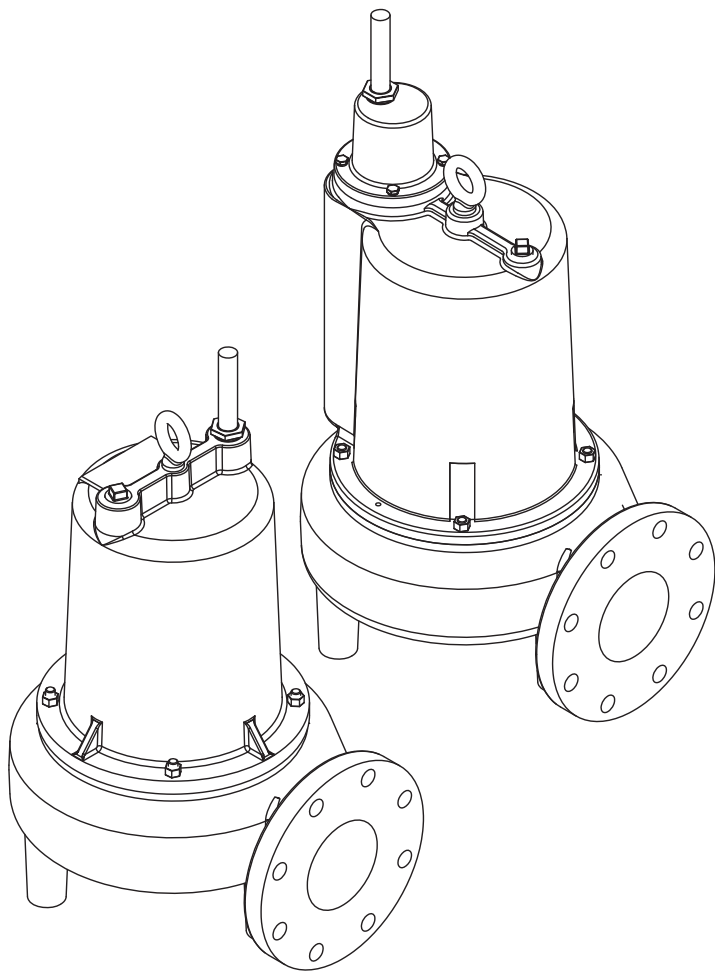

**Series: CP4NC2824SS
CP4NC2834SS, CP4NC2844SS
CP4NC3724SS, CP4NC3734SS,
CP4NC3744SS, CP4NC3764SS,
CP4NC5024SS, CP4NC5034SS,
CP4NC5044SS, CP4NC5064SS**

1750RPM, 60Hz

General Safety Information

Before installation, read the following instructions carefully. Failure to follow instruction and Safety information could cause serious bodily injury, death and/or property damage. Each Champion pump is individually factory tested to insure proper performance. Closely following these instructions will eliminate potential operating problems, assuring years of trouble-free service.

⚠ DANGER "Danger" indicates an imminently hazardous situation which, if not avoided, WILL result in death or serious injury.

⚠ WARNING "Warning" indicates an imminently hazardous situation which, if not avoided, MAY result in death or serious injury.

⚠ CAUTION "Caution" indicates a potentially hazardous situation which, if not avoided, MAY result in minor or moderate injury.

IMPORTANT - Champion Pump Company is not responsible for losses, injury or death resulting from failure to observe these safety precautions, misuse, abuse or misapplication of pumps or equipment.

 **ALL RETURNED PRODUCTS MUST BE CLEANED, SANITIZED, OR RECONTAMINATED PRIOR TO SHIPMENT, TO INSURE EMPLOYEES WILL NOT BE EXPOSED TO HEALTH HAZARDS IN HANDLING SAID MATERIAL. ALL APPLICABLE LAWS AND REGULATIONS SHALL APPLY.**

⚠ WARNING Installation, wiring, and junction connections must be in accordance with the National Electric Code and all applicable state and local codes. Requirements may vary depending on usage and location.

⚠ WARNING Installation and servicing is to be conducted by qualified personnel only.

⚠ DANGER Keep clear of suction and discharge openings. **Do not** insert fingers in pump with power connected.

⚠ WARNING Always wear eye protection when working on pumps. Do not wear loose clothing that may become entangled in moving parts

⚠ DANGER Pumps build up heat and pressure during operation. Allow time for pumps to cool before handling or servicing.

⚠ DANGER This pump is **not** intended for use in swimming pools or water installations where human contact with pumped fluid.

⚠ DANGER Risk of electric shock. To reduce risk of electric shock, always disconnect pump from power source before handling. **Lock out power & tag.**

⚠ WARNING Do not use these pumps in water over 104°F. High temperature units PFSE51HT 200°F. **Do not** exceed manufactures recommended maximum performance, as this could cause the motor to overheat.

⚠ DANGER Do not lift, carry or hang pump by the electrical cables. Damage to the electrical cables can cause shock, burnes or death. **Never** handle connected power cords with wet hands. Use appropriate lifting device.

⚠ WARNING Ground Fault Circuit Interrupter (GFCI) to be used with plug-in type power cord.

⚠ WARNING Sump and sewage pumps often handle materials which could cause illness or disease. wear adequate protective clothing when working on a used pump or piping. Never enter a basin after it has been used.

⚠ DANGER Failure to permanently ground the pump, motor and controls before connecting to power can cause shock, burns or death.

⚠ WARNING These pumps are NOT to be installed in locations classified as hazardous in accordance with the National Electric Code, ANSI/NFPA 70.

⚠ WARNING The Uniform Plumbing Code (UPC) states that sewage systems shall have an audio and visual alarm that signals a malfunction of the systems that is required to reduce the potential for property damage.

IMPORTANT! Prior to installation, record Model Number, MFG Date, Amps, Voltage, Phase and HP, from pump name plate for future reference. Also record the Voltage and Current Readings at Startup:

1 Phase Models	
Amps:	Volts:
3 Phase Models	
Amps L1-2:	Volts L1-2:
Amps L2-3:	Volts L2-3:
Amps L3-1:	Volts L3-1:

Model Number: _____

MFG Date: _____

PHASE: _____ HP: _____

Other brand and product names are trademarks or registered trademarks of their respective holders. Alteration Rights Reserved. 1/2011

DISCHARGE	4" 125 lb., Flange Horizontal
LIQUID TEMPERATURE	104°F
MOTOR HOUSING	Cast Iron, Class 30
VOLUTE	Cast Iron, Class 30
IMPELLER	2 vane open type with pump out vanes on back side, Dynamically balanced, ISO G6.3, Cast Iron, Class 30
SOLIDS HANDLING	3" spherical
SHAFT	Stainless steel
SEAL PLATE	Cast Iron, Class 30
PAINT	Air dry enamel
SQUARE RINGS	Buna-N
HARDWARE	Stainless steel
SEAL	Single mechanical, Inboard, Oil Filled reservoir, with Secondary Exclusion seal Silicon Carbide/Buna-N
UPPER BEARING	Single row, ball, oil lubricated
LOWER BEARING	Single row, ball, oil lubricated
POWER CORD	25 Ft. Cord. Epoxy sealed housing with secondary Pressure grommet for sealing and strain relief.
MOTOR	Class B Insulation, Oil Filled
SINGLE PHASE	Permanent Split Capacitor (PSC) Includes overload protection in motor
THREE PHASE	230/460 Volt. Dual Voltage. Requires overload protection to be included in control panel.

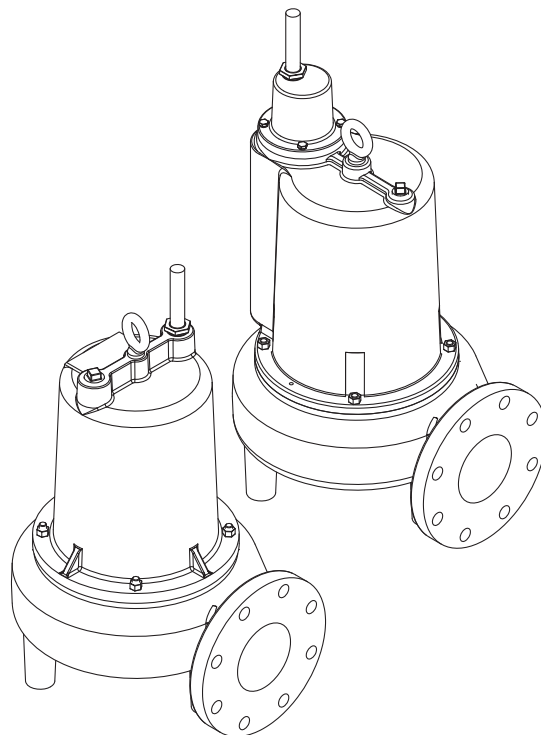

Dimensions

CP4NC2834SS, CP4NC2844SS

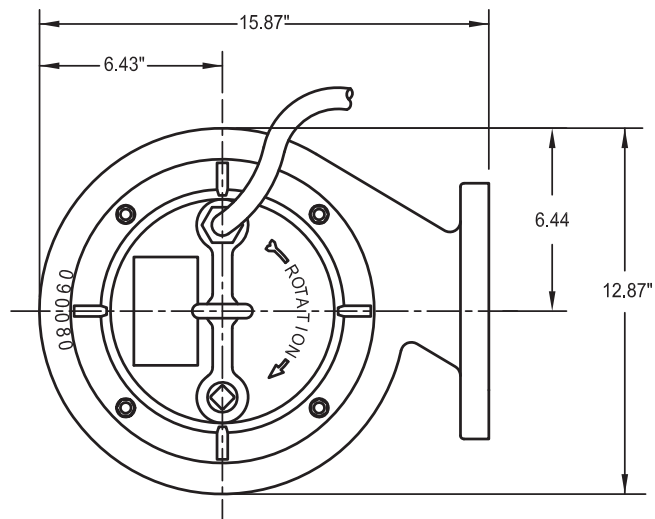
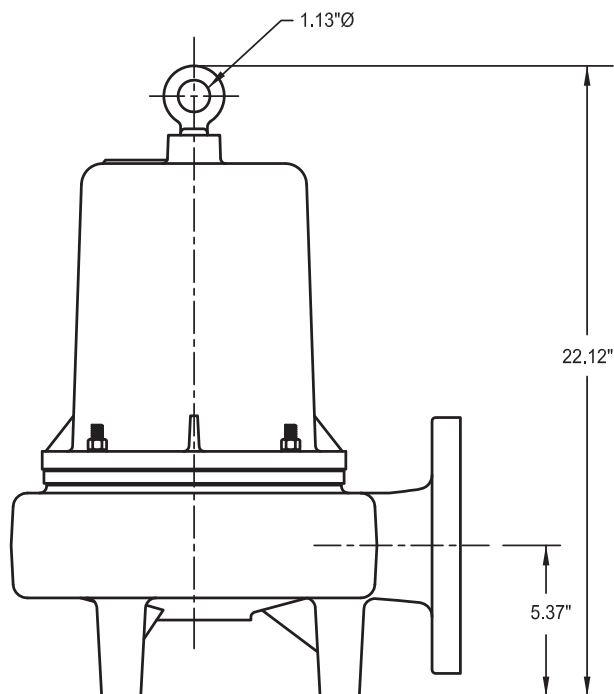

MODEL	HP	Hz	Volts/Ph	RPM	NEMA START CODE	FULL LOAD AMPS	LOCKED ROTOR AMPS	CORD SIZE	CORD TYPE	CORD O.D.
CP4NC2834SS	2.8	60	230/3	1750	E	8.0	35.0	10/4	SOW	0.75
CP4NC2844SS	2.8	60	460/3	1750	E	4.0	17.5	10/4	SOW	0.75

Winding resistance $\pm 5\%$ at terminal block.
 Rated operation at $\pm 10\%$ voltage at motor.

Dimensions

**CP4NC2824SS, CP4NC3724SS, CP4NC3734SS, CP4NC3744SS,
CP4NC3764SS, CP4NC5024SS, CP4NC5034SS, CP4NC5044SS,
CP4NC5064SS**

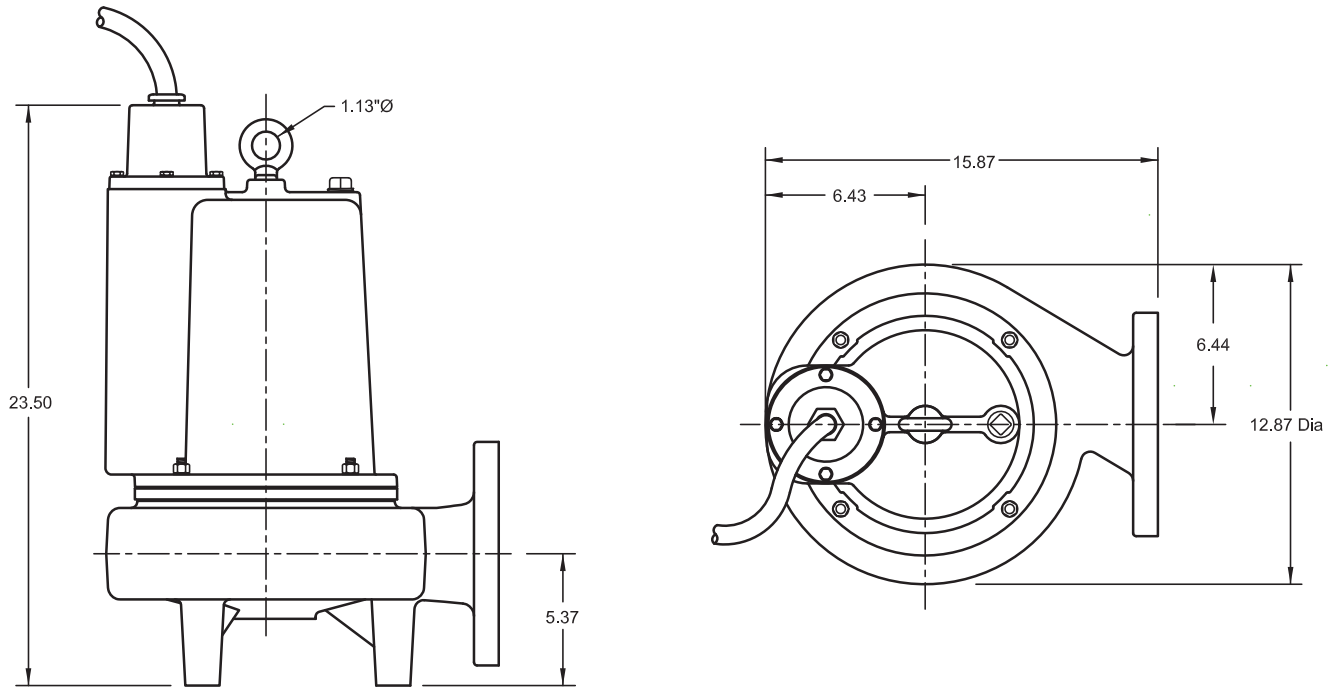

MODEL	HP	Hz	Volts/Ph	RPM	NEMA START CODE	FULL LOAD AMPS	LOCKED ROTOR AMPS	CORD SIZE	CORD TYPE	CORD O.D.
CC4NC2824SS	2.8	60	230/1	1750	A	12.6	23.0	10/3	SOW	0.69
CP4NC3724SS	3.7	60	230/1	1750	A	18.5	29.0	10/3	SOW	0.69
CP4NC3734SS	3.7	60	230/3	1750	F	14.0	50.8	10/4	SOW	0.75
CP4NC3744SS	3.7	60	460/3	1750	F	7.0	25.4	10/4	SOW	0.75
CP4NC3764SS	3.7	60	208/3	1750	D	15.4	44.1	10/4	SOW	0.75
CP4NC5024SS	5.0	60	230/1	1750	A	28.0	59.0	10/3	SOW	0.69
CP4NC5034SS	5.0	60	230/3	1750	D	19.0	56.0	10/4	SOW	0.75
CP4NC5044SS	5.0	60	460/3	1750	D	9.0	28.0	10/4	SOW	0.75
CP4NC5064SS	5.0	60	208/3	1750	B	20.9	48.6	10/4	SOW	0.75

Winding resistance $\pm 5\%$ at terminal block.
Rated operation at $\pm 10\%$ voltage at motor.

Performance

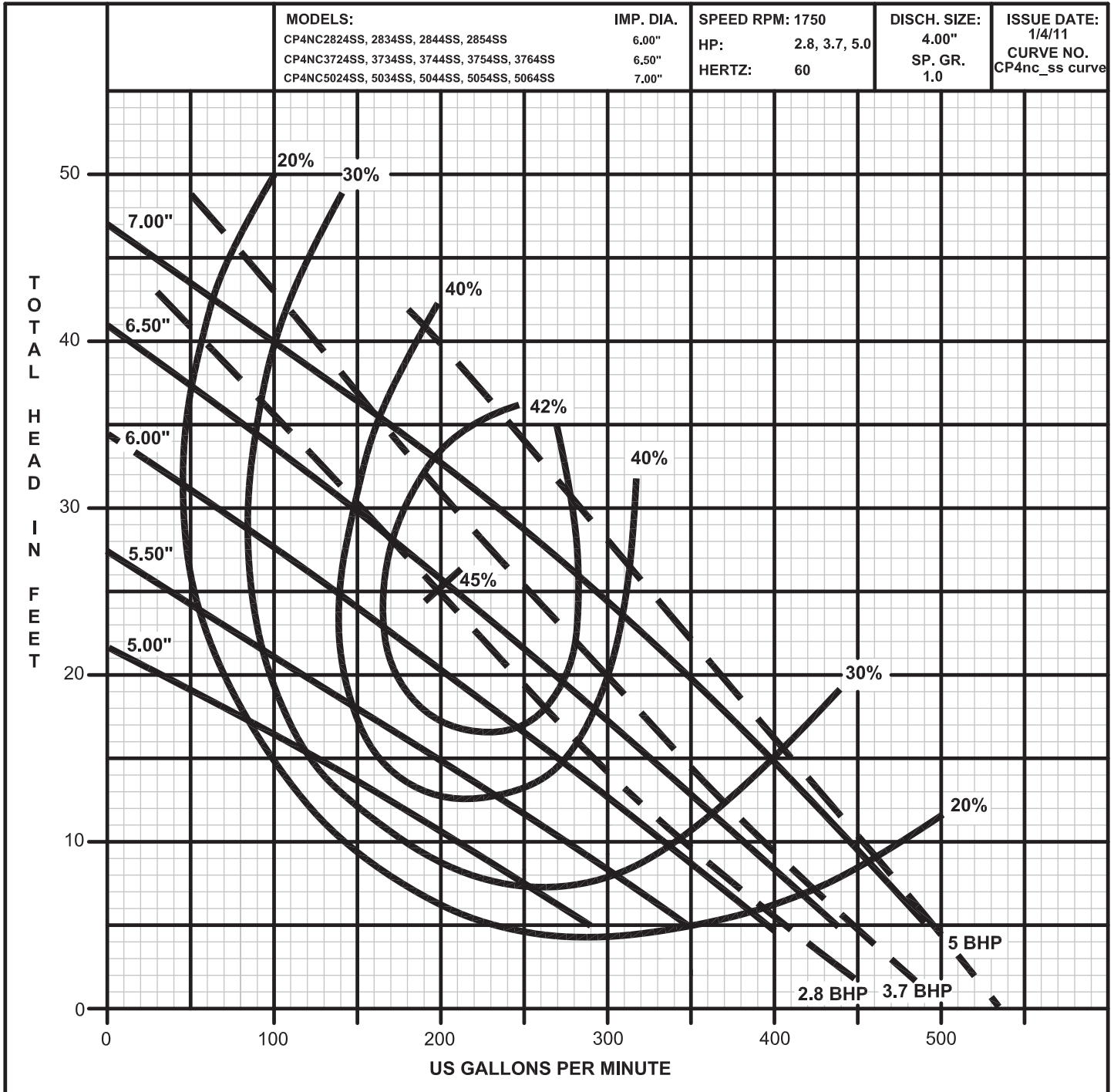

Receiving Inspection

Upon receiving the pump, it should be inspected for damage or shortages. If damage has occurred, file a claim immediately with the company that delivered the pump. If the manual is removed from the packaging, do not lose or misplace.

Storage

Any product that is stored for a period longer than six (6) months from the date of purchase should be bench tested prior to installation. A bench test consists of, checking the impeller to assure it is free turning and a run test to assure the motor (and switch if provided) operate properly. Do not pump out of liquid.

Controls

Manual models require a separate approved pump control device or panel for automatic operation. Be sure the electrical specification of the control selected properly match the electrical specifications of the pump.

Submergence

The pump should always be operated in the submerged condition. The minimum sump liquid level should never be less than above the pump's volute (See Figure 1).

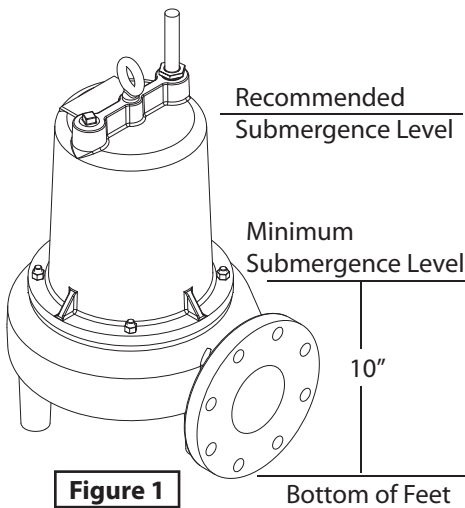

Figure 1

Installation

These pumps are recommended for use in a sump, basin or lift station. The sump, basin or lift station shall be sealed and vented in accordance with local plumbing codes. **This pump is designed to pump sewage, effluent or wastewater, nonexplosive and noncorrosive liquids and shall NOT be installed in locations classified as hazardous in accordance with the National Electrical Code (NEC) ANSI/NFPA 70 or Canadian Electric Code (CEC).** The pump should never be installed in a trench, ditch, or hole with a dirt bottom. The legs will sink into the dirt and the suction will become plugged.

The installation should be at a sufficient depth to ensure that all plumbing is below the frost line. If this is not feasible, remove the check valve and size the basin to accommodate the additional backflow volume.

Pumps are most commonly installed in simplex or duplex stations or basins with a slide rail system, which allows the pump(s) to be installed or removed without requiring personnel to enter the station, or resting on the basin floor.

Discharge Piping

Discharge piping should be as short as possible and sized no smaller than the pump discharge. **Do not reduce the discharge pipe size below that which is provided on the pump.** Both a check valve and a shut-off valve are recommended for each pump. The check valve is used to prevent backflow into the sump. The shut-off valve is used to manually stop system flow during pump servicing.

Liquid Level Controls

The level control(s) should be mounted on the discharge piping, a cable rack or float pole. The level control should have adequate clearance so it cannot hang up in its swing and that the pump is completely submerged when the level control is in the "Off" mode. By adjusting the cord tether the control level can be changed. One cycle of operation should be observed, so that any potential problems can be corrected.

It is recommended that the level control float should be set to insure that the liquid in the sump never drops below the top of the motor housing or a minimum level of 10 inches above the basin floor.

Electrical Connections

Power cable:

The power cable mounted to the pump must not be modified in any way except for shortening to a specific application. Any splice between the pump and the control panel must be made in accordance with the electric codes. It is recommended that a junction box, if used, be mounted outside the sump or be of at a minimum Nema 4 construction if located within the wet well. **DO NOT USE THE POWER CABLE TO LIFT PUMP.**

Always rely upon a Certified Electrician for installation.

Overload Protection:

Single Phase - The stator in-winding overload protector used is referred to as an inherent overheating protector and operates on the combined effect of temperature and current. This means that the overload protector will trip out and shut the pump off if the windings become too hot, or the load current passing through them becomes too high.

Installation & Service

IMPORTANT! - The overload will then automatically reset and start the pump up after the motor cools to a safe temperature. In the event of an overload, the source of this condition should be determined and corrected immediately.



WARNING! - DO NOT LET THE PUMP CYCLE OR RUN IF AN OVERLOAD CONDITION OCCURS!

If current through the temperature sensor exceeds the values listed, an intermediate control circuit relay must be used to reduce the current or the sensor will not work properly.

TEMPERATURE SENSOR ELECTRICAL RATINGS		
Volts	Continuous Amperes	Inrush Amperes
110-120	3.00	30.0
220-240	1.50	15.0
440-480	0.75	7.5
600	0.60	6.0

Wire Size:

If longer power cable is required consult a qualified electrician for proper wire size.

Pre-Operation

1. **Check Voltage and Phase** - Compare the voltage and phase information stamped on the pump name plate.
2. **Check Pump Rotation** - Improper motor rotation can result in poor pump performance and can damage the motor and/or pump. Check rotation on three phase units by momentarily applying power and observe the "kickback".

Kickback should always be in a counter-clockwise direction as viewed from **motor end** or **opposite** to impeller rotation. Impeller rotation is counter-clockwise as viewed from bottom of pump.

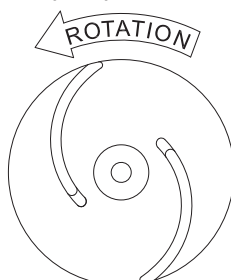

Bottom of Pump

3. **Name Plate** - Record the information from the pump name plate to drawing in front of manual for future reference.
4. **Insulation Test** - An insulation (megger) test should be performed on the motor. Before the pump is put into service. The resistance values (ohms) as well as the voltage (volts) and current (amps) should be recorded.
5. **Pump-Down Test** - Be sure pump has been properly wired, lowered into the basin, sump or lift station, check the system by filling with liquid and allowing the pump to operate through its pumping cycle. The time needed to empty the system, or pump-down time along with the volume of water, should be recorded.

Maintenance

No lubrication or maintenance is required. Perform the following checks when pump is removed from operation or when pump performance deteriorates:

- a). Inspect motor chamber for oil level and contamination.
- b). Inspect impeller and body for excessive build-up or clogging.
- c). Inspect motor, bearings and shaft seal for wear or leakage.

Servicing

NOTE: Item numbers in () refer to Figures 6 through 10.

Cooling Oil - Anytime the pump is removed from operation, the cooling oil in the motor housing should be checked visually for oil level and contamination. To check oil, set unit upright. Remove pipe plug (20) from housing (4). With a flashlight, visually inspect the oil in the housing (4) to make sure it is clean and clear, light amber in color and free from suspended particles. Milky white oil indicates the presence of water. Oil level should be just above the motor when pump is in vertical position.

Oil Testing

- Drain oil into a clean, dry container by placing pump on it's side, remove pipe plug (20), from housing (4).
- Check oil for contamination using an oil tester with a range to 30 Kilovolts breakdown.
- If oil is found to be clean and uncontaminated (measuring above 15 KV. breakdown), refill the housing.
- If oil is found to be dirty or contaminated (or measures below 15 KV. breakdown), the pump must be carefully inspected for leaks at the shaft seal, cable assembly, square ring and pipe plug, before refilling with oil. To locate the leak, perform a pressure test.

After leak is repaired, dispose of old oil properly, and refill with new oil.

Pressure Test (If oil has been drained)

Remove pipe plug (20) from housing (4). Apply pipe sealant to pressure gauge assembly and tighten into hole. Pressurize motor housing to 10 P.S.I. Use soap solution around the sealed areas and inspect joints for "air bubbles".

If, after five minutes, the pressure is still holding constant, and no "bubbles" are observed, slowly bleed the pressure and remove the gauge assembly. Replace oil. Leek must be located and repaired if pressure does not hold.

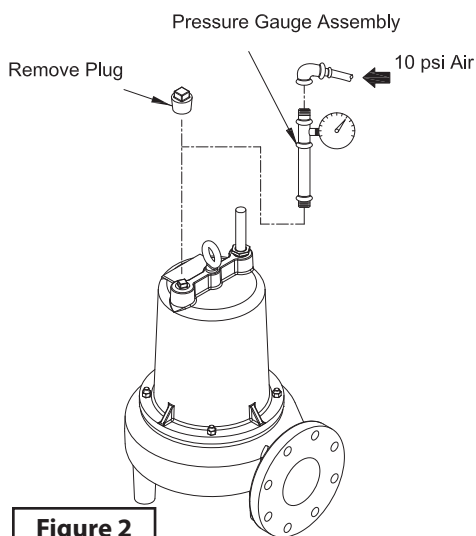

Figure 2

Pressure Test (If oil has NOT been drained)

Oil should be at normal level. Remove pipe plug (20) from housing (4). Apply pipe sealant to pressure gauge assembly and tighten into hole. Pressurize motor housing to 10 P.S.I. Use soap solution around the sealed areas above the oil level and inspect joints for "air bubbles". For sealed areas below oil level, leaks will seep oil. If, after five minutes, the pressure is still holding constant, and no "bubbles" /oil seepage is observed, slowly bleed the pressure and remove the gauge assembly. Replace oil. Leek must be located and repaired if pressure does not hold.



Pressure builds up extremely fast, increase pressure by "TAPPING" air nozzle. Too much pressure will damage seal. **DO NOT exceed 10 P.S.I.**

Oil Replacement - Set unit upright and refill with new cooling oil as per table below . Fill to just above motor, but below capacitor as an air space must remain in the top of the housing to compensate for oil expansion. Apply pipe thread compound to threads of pipe plug (20) then assemble to housing (14).



DO NOT overfill oil. Overfilling of housing with oil can create excessive and dangerous hydraulic pressure which can destroy the pump and create a hazard. Overfilling oil voids warranty.

Cooling Oil Recommended Supplier/Grade	
BP	Enerpar SE100
Conoco	Pale Paraffin 22
Mobile	D.T.E. Oil Light
Shell Canada	Transformer-10
Texaco	Diala-Oil-AX

Disassembly Impeller and Volute:

1. Disconnect power.
2. Remove hex nuts (9), vertically lift motor housing and seal plate assembly from volute (1). Clean out volute if necessary.
3. Inspect o-ring (19) and replace if cut or damaged.
4. Clean and examine impeller (2), for cracks or breakage and replace if required. To remove impeller (2), remove impeller nut (12) and washer (13). With a wheel puller, pull impeller straight off shaft and remove key (14).

5. Remove washer (15) and v-gasket (16) and remove if damaged.

Power Cord - CP4NC2834SS, 2844SS, 2854SS (See Figures 6 & 7):

6. Remove gland nut (23), friction ring (24), grommet (25) and friction ring (24) from motor housing (4). Pull cord through and disconnect the wires from the terminals (28).

Power Cord - CP4NC2824SS, 3744SS, 3734SS, 3744SS, 3754SS, 3764SS, 5024SS, 5034SS, 5044SS, 5054SS, 5064SS (See Figures 8, 9 & 10)

7. Remove cap screws (36) and washers (37), lift conduit box and cable assy (33) from motor housing (4). Disconnect the wires from the terminals (28). Remove o-ring (35) replace if damaged.

Motor & Capacitor:

8. Remove screws (17) and lift motor housing (4) from seal plate (3).
9. Remove o-ring (18), replace if damaged.
10. Remove motor bolts, lift motor stator assembly from seal plate (3).
11. On Single Phase units only (CP4NC2824SS, 3724SS, 5024SS). Check motor capacitor (34) with an Ohm meter by first grounding the capacitor by placing a screwdriver across both terminals and then removing screwdriver. Connect Ohm meter (set on high scale) to terminals. If needle moves to infinity (∞) then drifts back, the capacitor is good. If needle does not move or moves to infinity (∞) and does not drift back, replace capacitor (34).
12. Inspect motor winding for shorts and check resistance values. Check rotor for wear. If rotor or the stator windings are defective, the complete motor must be replaced.

Shaft Seal:

13. Unscrew conduit bushing (29) from seal plate (3) and lift motor rotor, shaft, bearing (8), rotating member of seal (6), washer (30) and conduit bushing (29) from seal plate (3). See Figure 3.

14. Remove seal parts (6) from shaft. Examine all seal parts, if seal faces show signs of wear, uneven wear pattern, chips or scratches replace entire seal. **DO NOT interchange seal components, replace the entire shaft seal (6).** If replacing seal, remove stationary from seal plate (3) by prying out with flat screwdriver.

Reassembly:



IMPORTANT! - All parts must be clean before reassembly. Handle seal parts with extreme care. DO NOT damage lapped surfaces.

Shaft Seal:

1. To reassemble, clean seal cavity in seal plate (3) and oil.

2. Press seal's (6) stationary member firmly into seal plate (3), use a seal tool or pipe. Nothing should come in contact with the seal face except the seal tool. Be sure the stationary is in straight.

3. Place conduit bushing (29) and washer (30) onto shaft. Press lower bearing (8) onto shaft.

4. Place seal's (6) retaining ring and spring onto shaft. Lightly oil (**Do not use grease**) shaft and inner surface of bellows.

5. With lapped surface of rotating member facing outward, slide over shaft using a seal tool, being careful not to damage seal face. Make sure spring is seated in retaining ring and spring is lined up on rotating member and not cocked or resting on bellows tail.

Bearing & Motor:

6. Slide rotor/shaft with bearing (8) and seal parts (6) into seal plate (3) until bearing seats into seal plate and tighten conduit bushing (29) into seal plate (3). Place stator over rotor, lining up motor bolts with holes in seal plate (3). Insert motor bolts and torque to 17 inch pounds.

7. On Single phase units, connect capacitor (34) to motor wires. See Figure 5.

8. On models **CP4NC2834SS, 2844SS, 2854SS**, place gland nut (23), one friction ring (24), grommet (25) and one friction ring (24) onto cord (22) and slide cord through hole in motor housing (4) (See Figure 4). Make wire connections per Figure 5.

9. On models **CP4NC2824SS, 3744SS, 3734SS, 3744SS, 3754SS, 3764SS, 5024SS, 5034SS, 5044SS, 5054SS, 5064SS**, place all motor leads above motor. Place o-ring (18) on seal plate (3) and lower motor housing (4) onto seal plate (3).

10. Place socket head screws (17) through seal plate into motor housing and torque to 60 inch pounds.

Impeller & Volute:

11. Install v-gasket (16) and impeller washer (15) over shaft, and into seal plate (3).

12. Install impeller (2) by applying a thin film of oil to motor shaft and slide impeller straight onto shaft, keeping keyways lined up. Drive key (14) into keyway.

13. Place washer (13) and impeller nut (12) onto shaft and torque to 40 ft lbs. Rotate impeller to check for binding.

14. Place o-ring (19) onto volute (1).

15. Lower motor housing and seal plate assembly onto volute (1). Apply thread locking compound to studs (9) and place hex nuts (4) onto studs and torque to 24 ft. lbs.

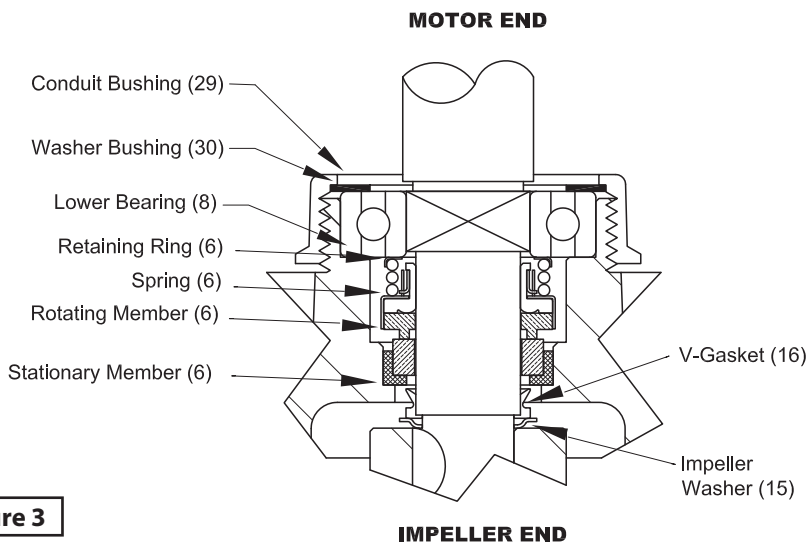

Figure 3

Models - CP4NC2824SS, 3744SS, 3734SS, 3744SS, 3754SS, 3764SS, 5024SS, 5034SS, 5044SS, 5054SS, 5064SS

16. Pull wires through large opening in motor housing (4) and connect wires with cord (22) in Conduit box (33) per schematic in Figure 5.

17. Refill with cooling oil and place o-ring (35) and conduit box (33) onto motor housing (4). Place cap screws (36) and washers (37) through conduit box into motor housing and tighten to 16 ft lbs.

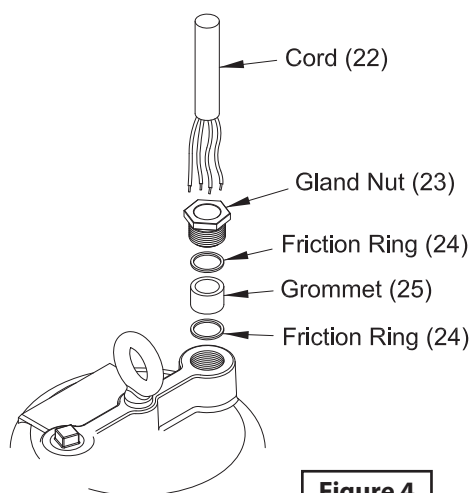
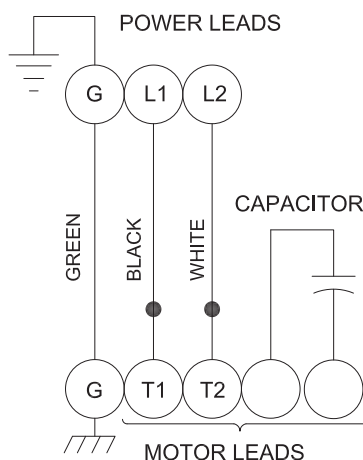

Figure 4

Cable Assembly:

18. For ALL Models - Check power cord (22) for cracks or damage and replace if required. Insert one friction ring (24), grommet (25), one friction ring (24), and gland nut (23) into motor housing (4) or conduit box & cable assembly (33) and torque gland nut (23) to 15 ft lbs.

19. on models **CP4NC2834SS, 2844SS, 2854SS**, refill with with cooling oil and replace pipe plug (20).



**Figure 5 - 115/230 Volt AC, 1Ph
Models: CP4NC2824SS, 3724SS, 5024SS**

Power Cable	Motor Lead Number
Green (Ground)	Green
Black	1
White	2
Flag Terminal	Capacitor
Flag Terminal	Capacitor

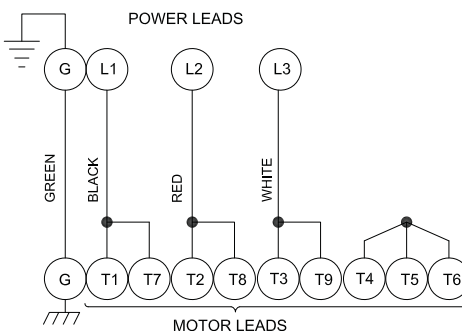

**Figure 5 - 208/230 Volt AC, 3Ph
Models: CP4NC2834SS, 3734SS, 3764SS, 5034SS, 5064SS**

Power Cable	Motor Lead Number
Green (Ground)	Green
Black	1 & 7
Red	2 & 8
White	3 & 9
	4, 5 & 6 Together

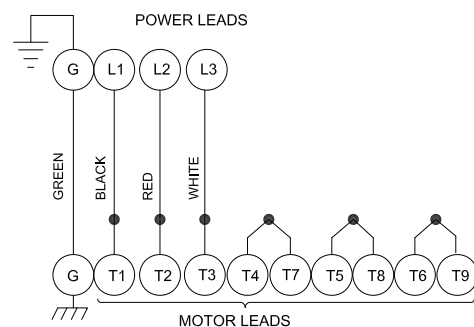

**Figure 5 - 460 Volt AC, 3Ph
Models: CP4NC2844SS, 3744SS, 5044SS**

Power Cable	Motor Lead Number
Green (Ground)	Green
Black	1
Red	2
White	3
	4 & 7 Together
	5 & 8 Together
	6 & 9 Together

Repair Parts

CP4NC2834SS, 2844SS

For Repair Part Please supply: Model Number and MFG Date as shown on Name Plate, and Part Description and Part Number as shown on Parts List.

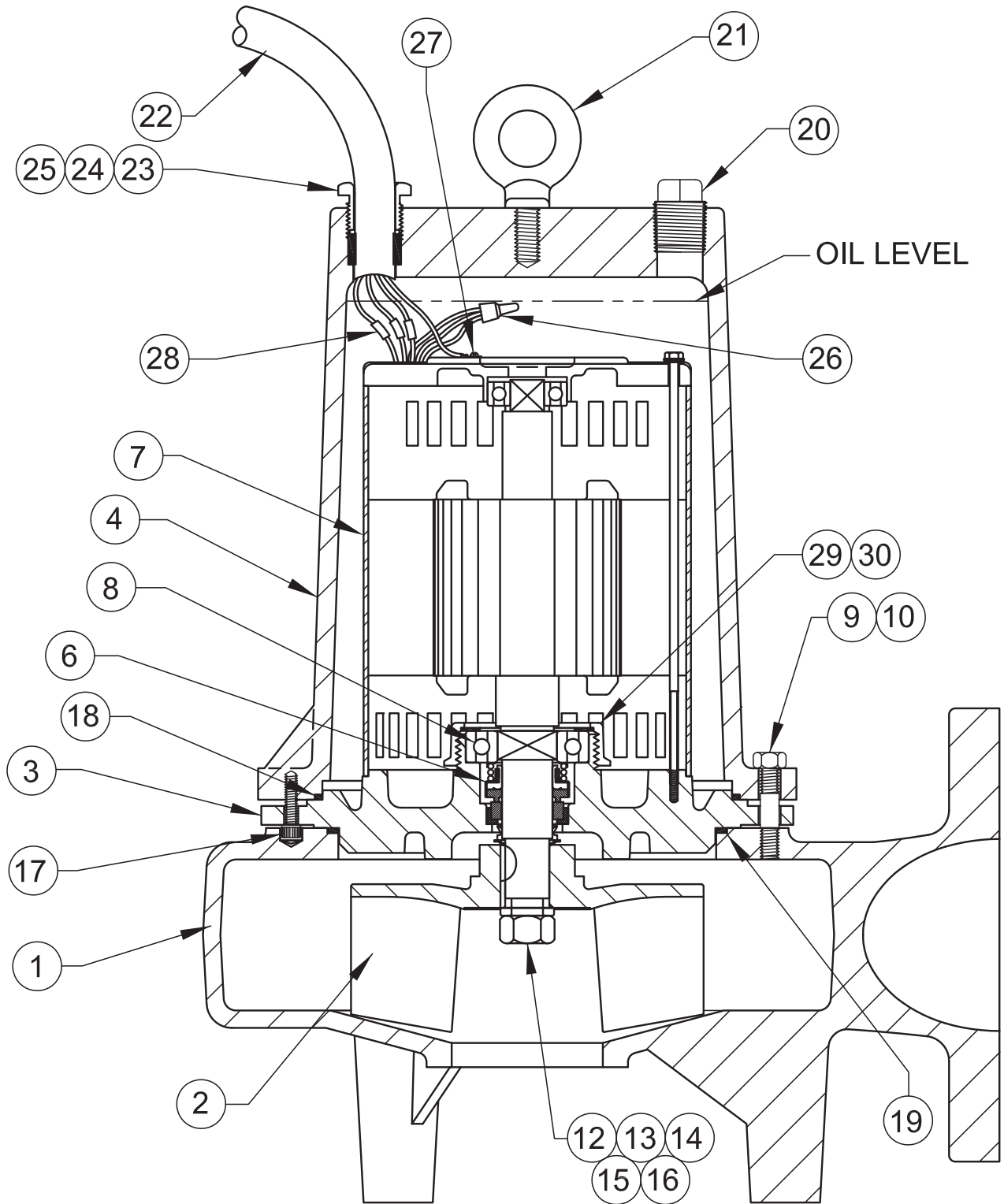

Figure 6

For Repair Part Please supply: Model Number and MFG Date as shown on Name Plate, and Part Description and Part Number as shown on Parts List.

CP4NC2834SS, 2844SS

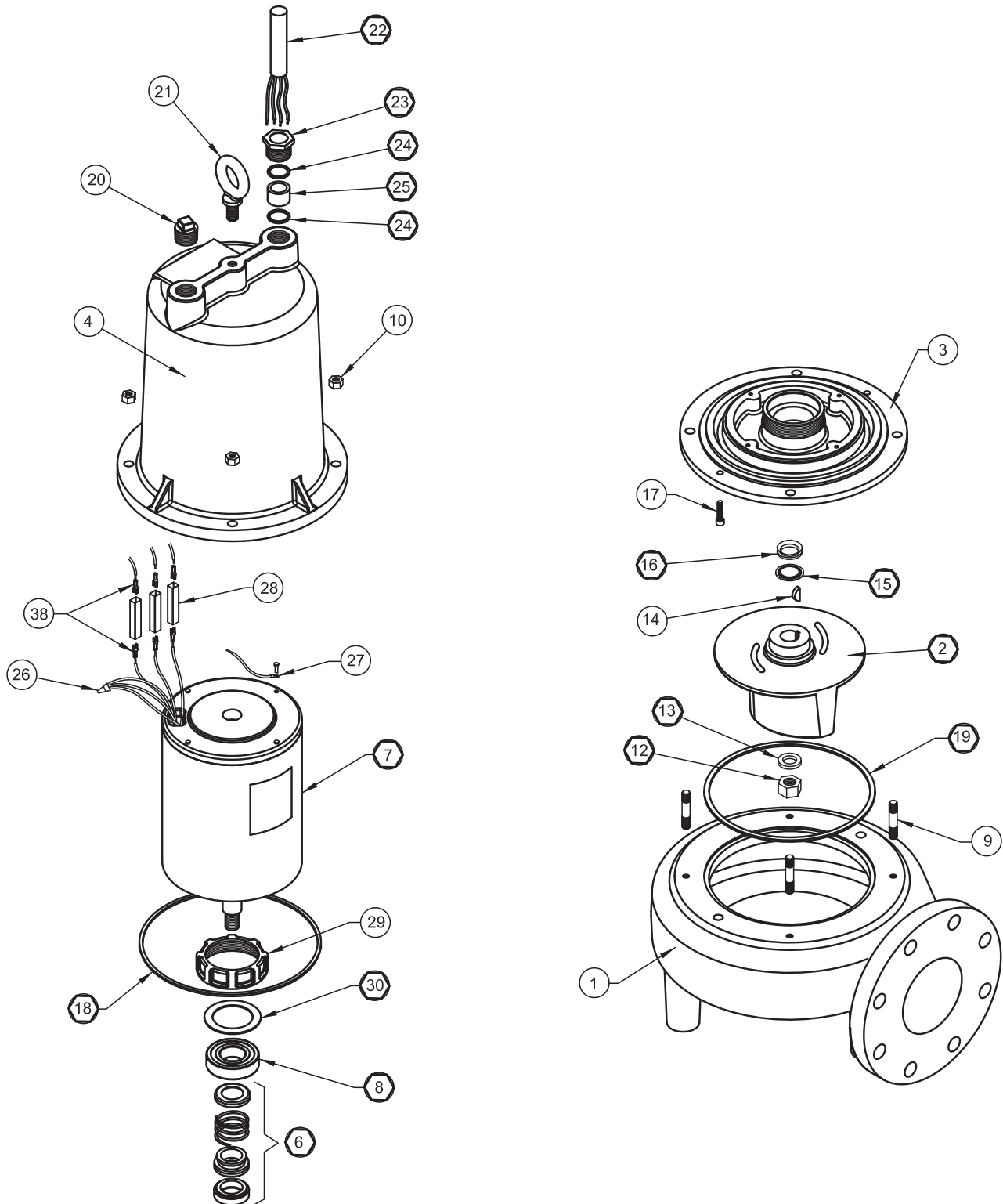

Figure 7

Parts List

CP4NC2834SS, 2844SS

For Repair Part Please supply: Model Number and MFG Date as shown on Name Plate, and Part Description and Part Number as shown on Parts List.

Ref. No.	Qty		Description	Used On	Part Numbers
1	1		Volute		PF03090080
2	1	☆	Impeller - 6.00" Dia		PF03140029C
3	1		Seal Plate		PF03180012
4	1		Motor Housing		PF03100002
6	1	◆	Shaft Seal - Silicon Carbide		PF31030152
7	2	☆	Motor #119, 2.8HP, 230/460, 3PH	CP4NC2834SS, 2844SS	PF40040005
8	1	◆	Ball Bearing		PF31020010
9	4		Stud 3/8-16 x 2" Lg, Stainless		◆
10	4		Hex Nut 3/8-16, Stainless		◆
12	1	◆	Impeller Nut 5/8-18, Stainless		PF91010442
13	1	◆	Washer 5/8, Stainless		PF91010063
14	1	◆	Shaft Key		PF91010111
15	1	◆	Washer, Impeller		PF91010051
16	1	◆	V-Gasket		PF92010112
17	2		Soc. Hd Cap Screw 1/4-20 x 1" Lg, Stainless		◆
18	1	◆	O-ring		PF92010083
19	1	◆	O-ring		PF92010082
20	1		Pipe Plug 3/4" NPT		◆
21	1		Eye Bolt 1/2-13 x 1" Lg.		◆
		☆	Power Cable Assy. Includes (*): 22, 23, 24, 25		PF053165
22	1	*	Power Cable, 25 Ft., 10/4, SOW		PF31030003
23	1	*	Gland Nut		PF30400903
24	2	*	Friction Ring		PF91010055
25	1	*	Grommet		PF92010001
26	1		Wire Connector		PF94010012
	3		Wire Connector		PF94010012
27	1		Eye terminal 3/16"		◆
28	3		Terminal Connector		PF94010027
29	1	◆	Conduit Bushing		PF31190021
30	1	◆	Washer Bushing		PF91010054
31	2		Screw 1/2-13 x 1.75" Lg, Stainless		◆
32	1		Lockwasher 1/2" Stainless		◆
38	6		Female Connector		PF94010041
39	1.5gal		Cooling Oil	Aquire locally - See chart on Page 8	

See Figures 6 & 7

See Page 20 For Kit Part Numbers

◆ = Aquire standard hardware locally.

◆ = Overhaul Kit

☆ = Supplied as individual items

For Repair Part Please supply: Model Number and MFG Date as shown on Name Plate, and Part Description and Part Number as shown on Parts List.

**CP4NC2824SS, 3724SS, 3734SS, 3744SS,
3764SS, 5024SS, 5034SS, 5044SS, 5064SS**

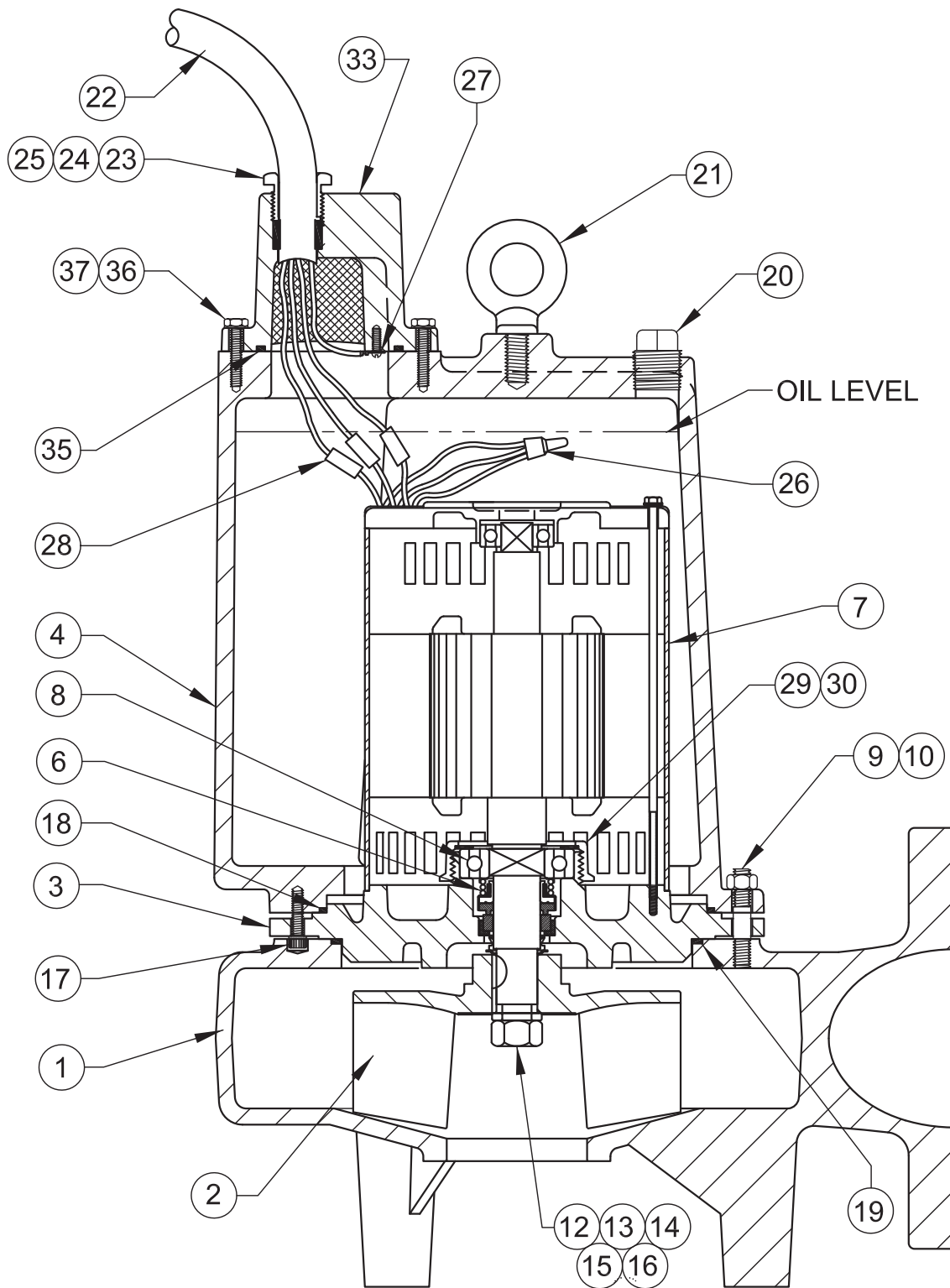

Figure 8

Parts List

CP4NC2824SS, 3724SS, 5024SS

For Repair Part Please supply: Model Number and MFG Date as shown on Name Plate, and Part Description and Part Number as shown on Parts List.

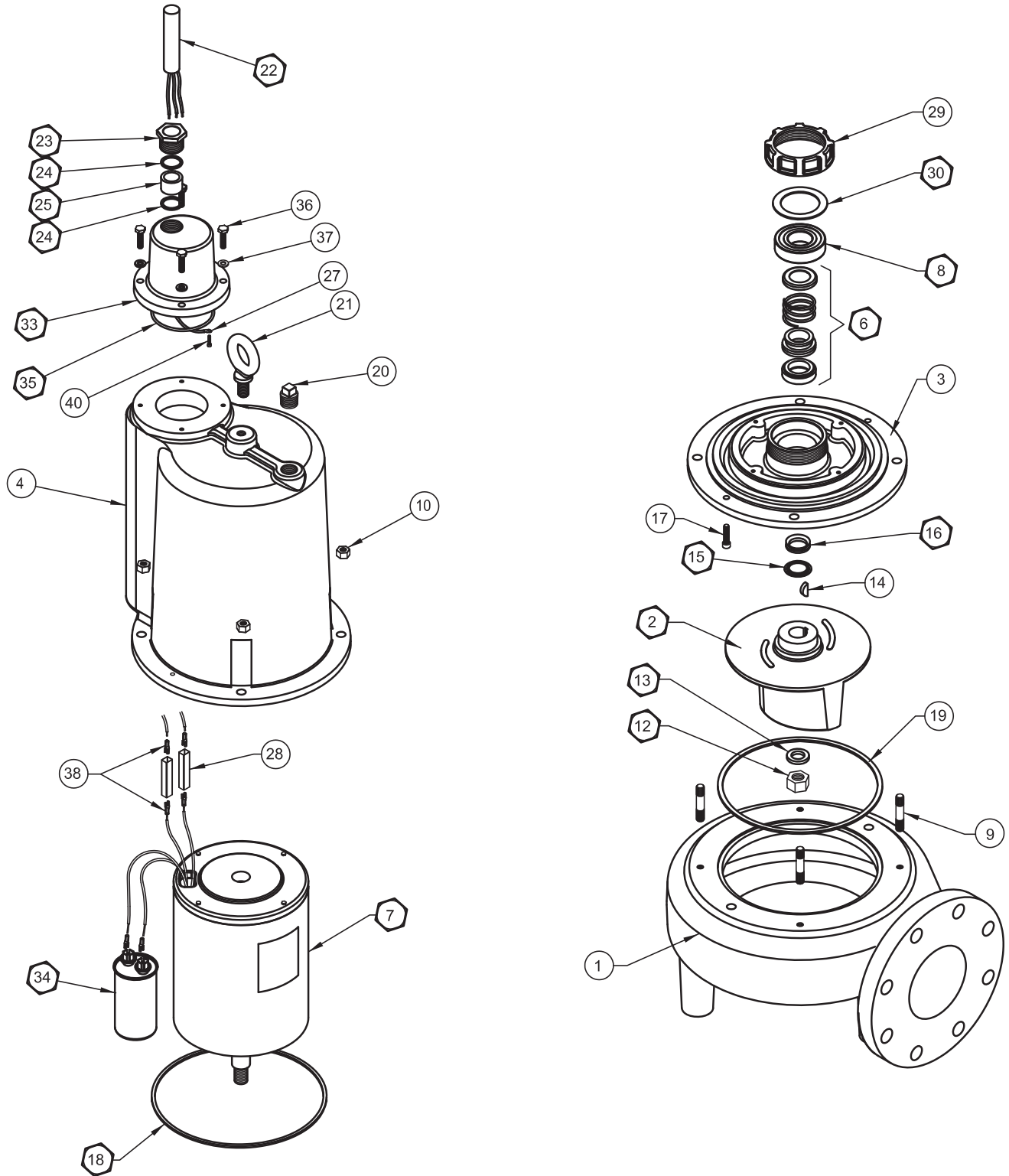

Figure 9

For Repair Part Please supply: Model Number and MFG Date as shown on Name Plate, and Part Description and Part Number as shown on Parts List.

CP4NC2824SS, 3724SS, 5024SS

Ref. No.	Qty		Description	Used On	Part Numbers
1	1		Volute		PF03090080
2	1	☆	Impeller - 6.00" Dia	CP4NC2824SS	PF03140029C
			Impeller - 6.50" Dia	CP4NC3724SS	PF03140077B
			Impeller - 7.00" Dia	CP4NC5024SS	PF03140077
3	1		Seal Plate		PF03180012
4	1		Motor Housing		PF03100009
6	1	●	Shaft Seal - Silicon Carbide		PF31030152
7	1	☆	Motor - 2.8, 3.7, 5HP, 230 V, 1Ph		PF40040061
8	1	●	Ball Bearing		PF31020010
9	4		Stud 3/8-16 x 2" Lg , Stainless		◆
10	4		Hex Nut 3/8-16, Stainless		◆
12	1	●	Impeller Nut 5/8-18, Stainless		PF91010442
13	1	●	Washer 5/8, Stainless		PF91010063
14	1	●	Shaft Key		PF91010111
15	1	●	Washer, Impeller		PF91010051
16	1	●	V-Gasket		PF92010112
17	2		Soc. Hd Cap Screw 1/4-20 x 1" Lg, Stainless		◆
18	1	●	O-ring		PF92010083
19	1	●	O-ring		PF92010082
20	1		Pipe Plug 3/4" NPT		◆
21	1		Eye Bolt 1/2-13 x 1" Lg.		◆
		☆	Power Cable Assy. Includes (*): 22, 23, 24, 25, 26, 27, 33, 35		PF085399
22	1	*	Power Cable, 25 Ft., 10/3, SOW		PF31030013
23	1	*	Gland Nut		PF30400903
24	2	*	Friction Ring		PF91010055
25	1	*	Grommet		PF92010001
27	1	*	Eye terminal 3/16"		◆
28	2		Terminal Connector		PF94010027
29	1	●	Conduit Bushing		PF31190021
30	1	●	Washer Bushing		PF91010054
31	2		Screw 1/2-13 x 1.75" Lg, Stainless		◆
32	1		Lockwasher 1/2" Stainless		◆
33	1	*	Conduit Box		PF03100010
34	1	☆	Capacitor, 45 MFD 370V		PF31030038
35	1	●*	O-ring		PF92010063
36	4		Cap screw 1/4-20 x 1" Lg Stainless		◆
37	4		Lockwasher 1/4" Stainless		◆
38	8		Female Connector		PF94010041
39	1.85gal		Cooling Oil	Aquire locally - See chart on Page 8	
40	1		Pan Hd Screw 6-32 x .375" Lg		◆

See Figures 8 & 9

◆ = Aquire standard hardware locally.

● = Overhaul Kit

☆ = Supplied as individual items

See Page 20 For Kit Part Numbers

Parts List

**CP4NC3734SS, 3744SS, 3764SS, 5034SS,
5044SS, 5064SS**

For Repair Part Please supply: Model Number and MFG Date as shown on Name Plate, and Part Description and Part Number as shown on Parts List.

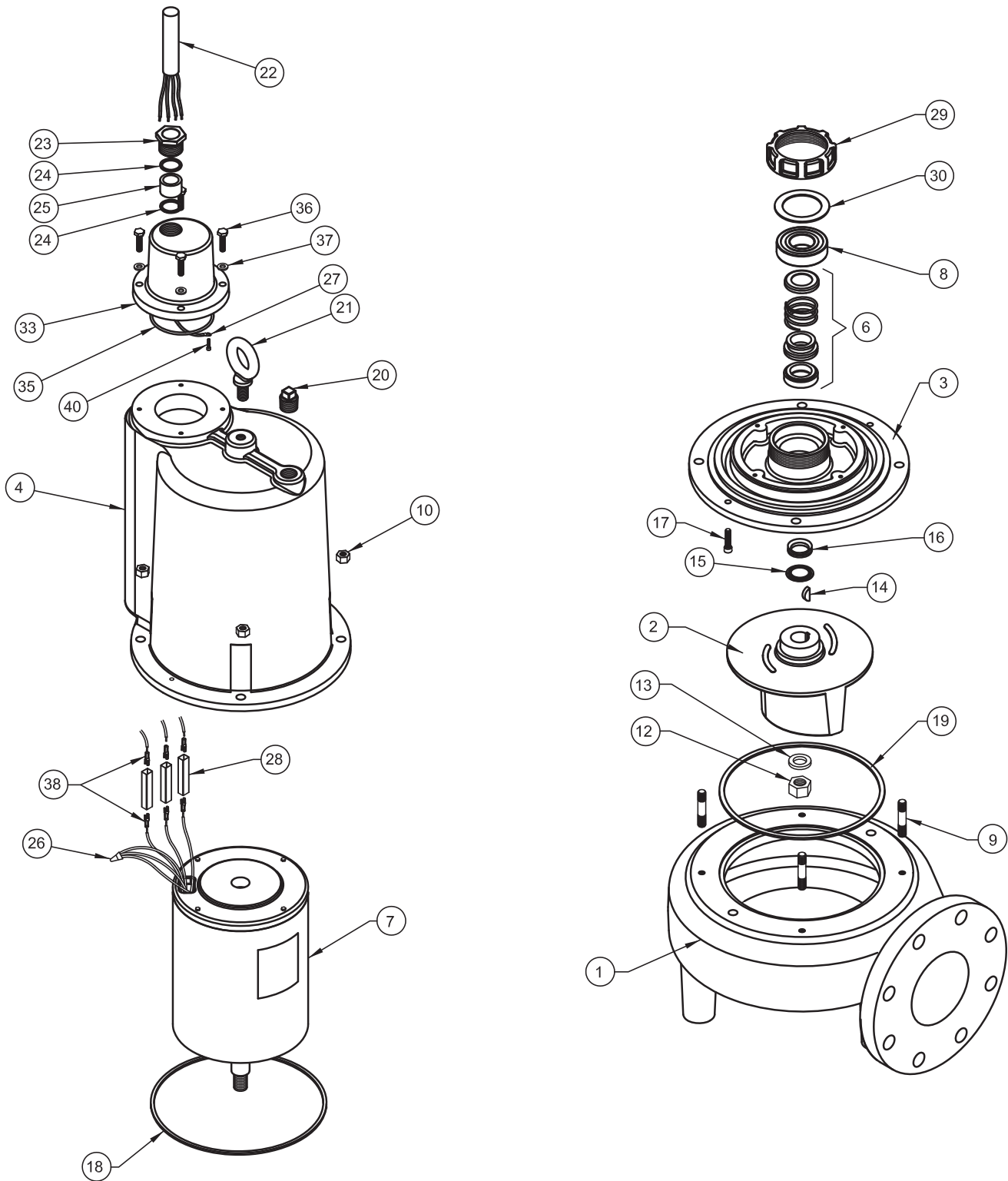

Figure 10

Champion Pump Company, Inc • P.O. Box 528 • Ashland, OH 44805
Phone 419-281-4500 • toll free 800-659-4491 • fax 419-616-1100

Parts List

For Repair Part Please supply: Model Number and MFG Date as shown on Name Plate, and Part Description and Part Number as shown on Parts List.

CP4NC3734SS, 3744SS, 3764SS, 5034SS, 5044SS, 5064SS

Ref. No.	Qty		Description	Used On	Part Numbers
1	1		Volute		PF03090080
2	1	☆	Impeller - 6.50" Dia	PF4NC3734SS, 3744SS, 3764SS	PF03140077B
			Impeller - 7.00" Dia	PF4NC 5034SS, 5044SS, 5064SS	PF03140077
3	1		Seal Plate		PF03180012
4	1		Motor Housing		PF03100009
6	1	●	Shaft Seal - Silicon Carbide		PF31030152
7	1	☆	Motor - 3.7, 5HP, 230/460 V, 3Ph		PF40040006
8	1	●	Ball Bearing		PF31020010
9	4		Stud 3/8-16 x 2" Lg, Stainless		◆
10	4		Hex Nut 3/8-16, Stainless		◆
12	1	●	Impeller Nut 5/8-18, Stainless		PF91010442
13	1	●	Washer 5/8, Stainless		PF91010063
14	1	●	Shaft Key		PF91010111
15	1	●	Washer, Impeller		PF91010051
16	1	●	V-Gasket		PF92010112
17	2		Soc. Hd Cap Screw 1/4-20 x 1" Lg, Stainless		◆
18	1	●	O-ring		PF92010083
19	1	●	O-ring		PF92010082
20	1		Pipe Plug 3/4" NPT		◆
21	1		Eye Bolt 1/2-13 x 1" Lg.		◆
		☆	Power Cable Assy., Includes (*): 22, 23, 24, 25, 27, 33		PF085092
22	1	*	Power Cable, 25 Ft., 10/4, SOW		PF31030003
23	1	*	Gland Nut		PF30400903
24	2	*	Friction Ring		PF91010055
25	1	*	Grommet		PF92010001
26	1		Wire Connector	PF4NC3734SS, 5034SS	PF94010012
	3		Wire Connector	PF4NC3744SS, 5044SS	PF94010012
27	1	*	Eye terminal 3/16"		PF94010043
28	2		Terminal Connector	PF4NC3734SS, 3744SS, 5034SS, 5044SS	PF94010027
	3		Terminal Connector	PF4NC3764SS, 5064SS	PF94010027
29	1	●	Conduit Bushing		PF31190021
30	1	●	Washer Bushing		PF91010054
31	2		Screw 1/2-13 x 1.75" Lg, Stainless		◆
32	1		Lockwasher 1/2" Stainless		◆
33	1	*	Conduit Box		PF03100010

See Figures 8 & 10

◆ = Acquire standard hardware locally.

● = Overhaul Kit

☆ = Supplied as individual items

See Page 20 For Kit Part Numbers

Parts List

**CP4NC3734SS, 3744SS, 3764SS, 5034SS,
5044SS, 5064SS**

For Repair Part Please supply: Model Number and MFG Date as shown on Name Plate, and Part Description and Part Number as shown on Parts List.

Ref. No.	Qty		Description	Used On	Part Numbers
35	1	◆	O-ring		PF92010063
36	4		Cap screw 1/4-20 x 1" Lg Stainless		◆
37	4		Lockwasher 1/4" Stainless		◆
38	6		Female Connector		PF94010041
39	1.85gal		Cooling Oil	Acquire locally - See chart on Page 8	
40	1		Pan Hd Screw 6-32 x .375" Lg		◆
Repair Kit					
◆	OVERHAUL KIT - Includes: 6, 8, 12, 13, 14, 15, 16, 18, 19, 29, 30, 35				PF4NCSS-OHK

See Figures 8 & 10

- ◆ = Acquire standard hardware locally.
- ◆ = Overhaul Kit
- ☆ = Supplied as individual items



Risk of electric shock. Always disconnect the pump from the power source before handling inspections or repairs.

Symptom	Possible Cause(s)	Corrective Action
Pump will not run	<ol style="list-style-type: none"> 1. Poor electrical connection, blown fuse, tripped breaker or other interruption of power; improper power supply 2. Motor or switch inoperative (go to manual operation) <ol style="list-style-type: none"> 2a. Float movement restricted 2b. Switch will not activate pump or is defective 2c. Defective motor 3. Insufficient liquid level 	<ol style="list-style-type: none"> 1. Check all electrical connections for security. Have electrician measure current in motor leads, if current is within $\pm 20\%$ of locked rotor Amps, impeller is probably locked. If current is 0, overload may be tripped. Remove power, allow pump to cool, then re-check current. 2a. Reposition pump or clean basin as required to provide adequate clearance for float 2b. Disconnect level control. Set ohmmeter for a low range, such as 100 ohms full scale and connect to level control leads. Actuate level control manually and check to see that ohmmeter shows zero ohms for closed switch and full scale for open switch. (Float Switch) 2c. Check winding insulation (Megger Test) and winding resistance. If check is outside of range, dry and re-check. If still defective, replace per service instructions. 3. Make sure liquid level is above the pump 4. Re-check all sizing calculations to determine proper pump size. 5. Check discharge line for restrictions, including ice if line passes through or into cold areas. 6. Remove and examine check valve for proper installation and freedom of operation 7. Open valve 8. Check impeller for freedom of operation, security and condition. Clean impeller cavity and inlet of any obstruction 9. Loosen union slightly to allow trapped air to escape. Verify that turn-off level of switch is set so that the suction is always flooded. Clean vent hole 10. Check rotation. If power supply is three phase, reverse any two of three power supply leads to ensure proper impeller rotation 11. Repair fixtures as required to eliminate leakage 12. Check pump temperature limits and fluid temperature 13. Replace portion of discharge pipe with flexible connector or tighten existing piping. 14. Turn to automatic position 15. Check for leaks around basin inlet and outlets
Pump will not turn off	<ol style="list-style-type: none"> 2a. Float movement restricted 2b. Switch will not activate pump or is defective 4. Excessive inflow or pump not properly sized for application 9. Pump may be air locked causing pump not to flow 14. H-O-A switch on panel is in "HAND" position 	
Pump hums but doesn't run	<ol style="list-style-type: none"> 1. Incorrect low voltage 8. Impeller jammed or loose on shaft, or inlet plugged 	
Pump delivers insufficient capacity	<ol style="list-style-type: none"> 1. Incorrect low voltage 4. Excessive inflow or pump not properly sized for application 5. Discharge restricted 6. Check valve partially closed or installed backwards 7. Shut-off valve closed 8. Impeller jammed or loose on shaft, or inlet plugged 9. Pump may be air locked causing pump not to flow 10. Piping fixtures leaking or discharge before the nozzle 	
Pump cycles too frequently or runs periodically when fixtures are not in use	<ol style="list-style-type: none"> 6. Check valve partially closed or installed backwards 11. Fixtures are leaking 15. Ground water entering basin 	
Pump shuts off and turns on independent of switch, (trips thermal overload protector). CAUTION! Pump may start unexpectedly. Disconnect power supply.	<ol style="list-style-type: none"> 1. Incorrect low voltage 4. Excessive inflow or pump not properly sized for application 8. Impeller jammed or loose on shaft, or inlet plugged 12. Excessive water temperature (internal protection only) 	
Pump operates noisily or vibrates excessively	<ol style="list-style-type: none"> 2c. Worn bearings, motor shaft bent 5. Debris in impeller cavity or broken impeller 10. Pump running backwards 13. Piping attachments to building structure too loose or rigid 	

NOTE: Power-Flo Pumps & Systems assumes no responsibility for damage or injury due to disassembly in the field. Disassembly of the pumps or supplied accessories other than at Power-Flo Pumps & Systems or its authorized service centers, automatically voids warranty.

LIMITED WARRANTY

Manufacturer warrants, to the immediate purchaser and subsequent initial owner during the warranty period, every new pump to be free from defects in material and workmanship under normal use and service, when properly used and maintained, for a period of eighteen (18) months from date of manufacture or twelve (12) months from date of installation (whichever ever comes first). Failure due to wear due to excessive abrasives is not covered. The initial owner is the purchaser who first uses the pump after its initial installation, or for non-permanent installation, the first owner who uses the pump. The date of installation shall be determined by a dated sales receipt noting the model and serial number of the pump. The dated sales receipt must accompany the returned pump. Product will be repaired, replaced or remanufactured at Manufacturer's option. No allowance will be made for shipping charges, damages, labor or other charges that may occur due to product failure, repair or replacement. This warranty does not apply to and there shall be no warranty for any material or product that has been disassembled without prior approval of Manufacturer, subjected to misuse, misapplication, neglect, alteration, accident or act of God; that has not been installed, operated or maintained in accordance with Manufacturer's installation instructions; that has been exposed to outside substances including but not limited to the following: sand, gravel, cement, mud, tar, hydrocarbons, hydrocarbon derivatives (oil, gasoline, solvents, etc.), or other abrasive or corrosive substances, wash towels or feminine sanitary products, etc. in all pumping applications. The warranty set out in the paragraph above is in lieu of all other warranties expressed or implied; and we do not authorize any representative or other person to assume for us any other liability in connection with our products. Contact Manufacturer to obtain any needed repair or replacement of part(s) or additional information pertaining to our warranty.

MANUFACTURER EXPRESSLY DISCLAIMS LIABILITY FOR SPECIAL, CONSEQUENTIAL OR INCIDENTAL DAMAGES OR BREACH OF EXPRESSED OR IMPLIED WARRANTY; AND ANY IMPLIED WARRANTY OF FITNESS FOR A PARTICULAR PURPOSE AND OF MERCHANTABILITY SHALL BE LIMITED TO THE DURATION OF THE EXPRESSED WARRANTY.

Some states do not allow limitations on the duration of an implied warranty, so the above limitation may not apply to you. Some states do not allow the exclusion or limitation of incidental or consequential damages, so the above limitation or exclusion may not apply to you. This warranty gives you specific legal rights and you may also have other rights which vary from state to state.

www.championpump.com

Start-Up Report / Warranty Registration

Please fill out the following questions as completely and accurate as possible. Please mail to Champion Pump Company, Inc. – P. O. Box 528 – Ashland, OH 44805.

REPORTS THAT ARE NOT RETURNED CAN DELAY OR VOID WARRANTY.

Pump Owner's

Name: _____

Address: _____

Location of installation: _____

Phone: _____

Purchased from: _____

Pump Model _____ Serial # _____ Date Code: _____

NOTE: PUMPS REQUIRING CAPACITORS IN THE PANELS MUST HAVE PROPER CAPACITOR KIT OR WARRANTY IS VOID.

Date Installed: _____

Does impeller turn freely by hand? YES _____ NO _____

Condition of cord jacket? Good _____ Fair _____ Poor _____

Was equipment stored? _____ How long? _____

Liquid being pumped _____

Debris in bottom of station? _____ Was debris removed in your presence? _____

Discharge pipe size? _____ Length of pipe? _____ Static lift? _____

Does station appear to operate at the proper rate? _____ Pump down time? _____

Voltage At Wiring Terminal L1-L2 _____ L2-L3 _____ L1-L3 _____

Run Amps L1 _____ L2 _____ L3 _____

3 Phase Models – Check Proper Rotation? Yes / NO

Difficulties during start up: _____

I certify this report to be accurate (start up person) _____

Employed by _____ Date: _____